

# NEXQC SERIES

Petroleum Analysis by X-ray Fluorescence

Affordable EDXRF Elemental Analyzers

Sulfur	Chlorine	Nickel	Vanadium	Iron	Lead	Manganese	Phosphorus	Calcium	Zinc	Molybdenum
<b>S</b> 16	<b>Cl</b> 17	<b>Ni</b> 28	<b>V</b> 23	<b>Fe</b> 26	<b>Pb</b> 82	<b>Mn</b> 25	<b>P</b> 15	<b>Ca</b> 20	<b>Zn</b> 30	<b>Mo</b> 42
Atomic Weight = 32.07	Atomic Weight = 35.45	Atomic Weight = 58.69	Atomic Weight = 50.94	Atomic Weight = 55.85	Atomic Weight = 207.20	Atomic Weight = 54.94	Atomic Weight = 30.97	Atomic Weight = 40.08	Atomic Weight = 65.38	Atomic Weight = 95.96



# Rigaku

Applied Rigaku Technologies, Inc.



## NEX QC Series Sulfur in Oil Analyzers Combine Established Functionality with Unmatched Versatility for ASTM D4294

Sulfur will always be an important element in crude oils and fuel oils. Sulfur content is regulated in many products and plays a significant role in the quality of fuel and polluting emissions. Regulations worldwide limit the amount of sulfur allowable in diesel fuels, kerosene, heating oils, etc., thus affecting the price and quality of crude oil based on its sulfur content.

Reliably characterizing the sulfur content of crudes ensures proper quality for the various feedstocks at the refinery, and optimum blending ratios when combining different crudes to meet the desired sulfur concentration. Monitoring sulfur is also critical when characterizing other similar oils, like residual oils and bunker fuels. To meet the industry's needs, Rigaku offers the NEX QC Series, simple and versatile benchtop EDXRF analyzers for the analysis of sulfur and other elements in crude oil, petroleum oils, and fuels.

### Modern Design & Functionality

As premium low-cost benchtop energy dispersive X-ray fluorescence (EDXRF) analyzers, the NEX QC Series deliver compliance with ASTM D4294 with an easy-to-learn software interface in a robust package specially designed for the petroleum industry. Optimized for routine determination of sulfur in oil, the NEX QC Series feature a modern icon-driven touchscreen interface for intuitive operation and a built-in thermal printer for convenience.

### Superior EDXRF Capabilities

A 50 kV X-ray tube and Peltier cooled solid-state detector deliver exceptional short-term repeatability and long-term reproducibility with excellent element peak resolution. The high voltage capability, along with multiple automated tube filters, provides multi-element analysis capability for unmatched performance and low limits of detection (LOD).

# Computational Dexterity

Powered by sophisticated software, the NEX QC Series analyzers are remarkably easy to use. Empirical calibration curves may be linear, quadratic, or hyperbolic fits. To compensate for the presence of other elements in oil, intensity-based, or concentration-based alpha ( $\alpha$ ) corrections may be enabled. C/H correction is also available to compensate for light element matrix changes in the oil and the presence of low atomic number (low-Z) additives and contaminants. With the touch of a finger, all calibration functions are accessible via intuitive icons.



Instrument status, spectra, and analytical results are icon selectable with the touch of a finger

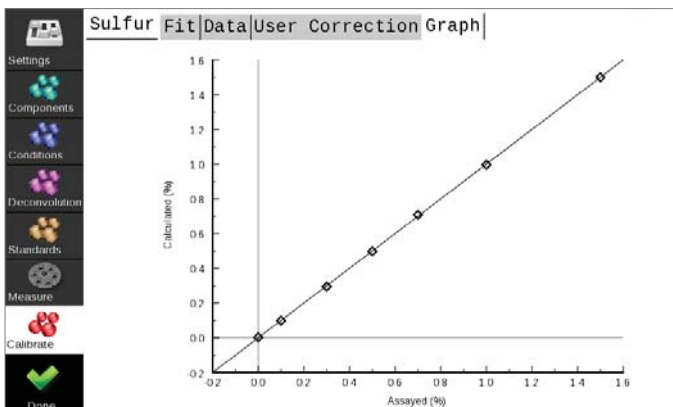

Calibration curves and statistics are readily accessible with icon-driven menus.

<b>Sample ID:</b>	<b>tank 11</b>
<b>Timestamp:</b>	10:10:07 2012-07-27
<b>Instrument:</b>	NEX QC S/N QC1002
<b>Product:</b>	S in Diesel High Range
<b>Total Acquisition Time:</b>	100 sec
ID	Result
Sulfur	0.071 %

<b>Sample ID:</b>	<b>tank 19</b>
<b>Timestamp:</b>	10:40:07 2012-07-27
<b>Instrument:</b>	NEX QC S/N QC1002
<b>Product:</b>	S in Diesel High Range
<b>Total Acquisition Time:</b>	100 sec
ID	Result
Sulfur	0.104 %

<b>Sample ID:</b>	<b>tank 99</b>
<b>Timestamp:</b>	12:47:07 2012-07-27
<b>Instrument:</b>	NEX QC S/N QC1002
<b>Product:</b>	S in Diesel High Range
<b>Total Acquisition Time:</b>	100 sec
ID	Result
Sulfur	0.471 %

Paper copies of analytical results are conveniently available from the front-mounted thermal printer.

## Backed by Rigaku

Since its inception in 1951, Rigaku has been at the forefront of analytical and industrial instrumentation technology. With hundreds of major innovations to their credit, the Rigaku group of companies are world leaders in the field of analytical X-ray instrumentation. Rigaku employs over 1,400 people worldwide in operations based in Japan, the U.S., Europe, South America, and China.

## Analyze for Sulfur & Other Elements

A periodic table with several elements highlighted in different colors. A red arrow points from the highlighted elements to a larger graphic of the element Sulfur.

Sulfur

S

16

Atomic Weight = 32.07

### ✓ Touchscreen Interface

High-resolution, modern, user-friendly touchscreen navigation and instrument control with angle adjustment for glare-free viewing.

### ✓ Accepts Standard XRF Cups

No special cups needed. Use industry-standard Chemplex®, SPEX®, VHG™, or PREMIER™ sample cups.

### ✓ Up to 38 Calibrations

At the touch of a finger, many calibrations are available to support a vast array of applications and sample types.

### ✓ Installation Made Easy

Designed to be user installed and maintained.

### ✓ Built-in Printer

The thermal printer provides fast hard copy results when and where you need them.

### ✓ X-ray tube Conservation

Minimized X-ray tube wear and tear by operating only during data collection — lowering operating costs.

### ✓ Detector Protection Mechanism

An easily changeable plastic film is positioned in the sample holder to protect the instrument in the event of leaks or spills.



Single position sample holder showing "easy snap" leak protection mechanism.

Sulfur	Chlorine	Nickel	Vanadium	Iron	Lead	Manganese	Phosphorus	Calcium	Zinc	Molybdenum
<b>S</b> 16	<b>Cl</b> 17	<b>Ni</b> 28	<b>V</b> 23	<b>Fe</b> 26	<b>Pb</b> 82	<b>Mn</b> 25	<b>P</b> 15	<b>Ca</b> 20	<b>Zn</b> 30	<b>Mo</b> 42
Atomic Weight = 32.07	Atomic Weight = 35.45	Atomic Weight = 58.69	Atomic Weight = 50.94	Atomic Weight = 55.85	Atomic Weight = 207.20	Atomic Weight = 54.94	Atomic Weight = 30.97	Atomic Weight = 40.08	Atomic Weight = 65.38	Atomic Weight = 95.96



✓ **5 ppm Sulfur (S) Detection Limit**

ASTM D4294 method is met for diesel oil as analyzed in air. Repeatability is  $\pm 3.4$  ppm at 100 ppm with a 120-sec measurement in air.



✓ **1.3 ppm Sulfur (S) Detection Limit**

ISO 13032 method is met for diesel oil as analyzed in a helium atmosphere. Repeatability is  $\pm 0.5$  ppm at 10 ppm, with a 300-sec measurement in helium.



✓ **C/H Correction**

Correction is available to compensate for calibration error caused by different types of oil.

✓ **Digital Data Output**

Ethernet RJ-45 jack and USB port for output to LIMS or memory stick. Data is available in either CSV or PDF formats.

✓ **Single Position or Autosampler**

Supplement the standard single position configuration with an optional automatic sample changer.

✓ **Removable Sample Trays**

Interchangeable optional autosampler trays can be pre-loaded, or swapped in and out, to increase efficiency or where throughput is important. Supports 32 mm and 40 mm cups.

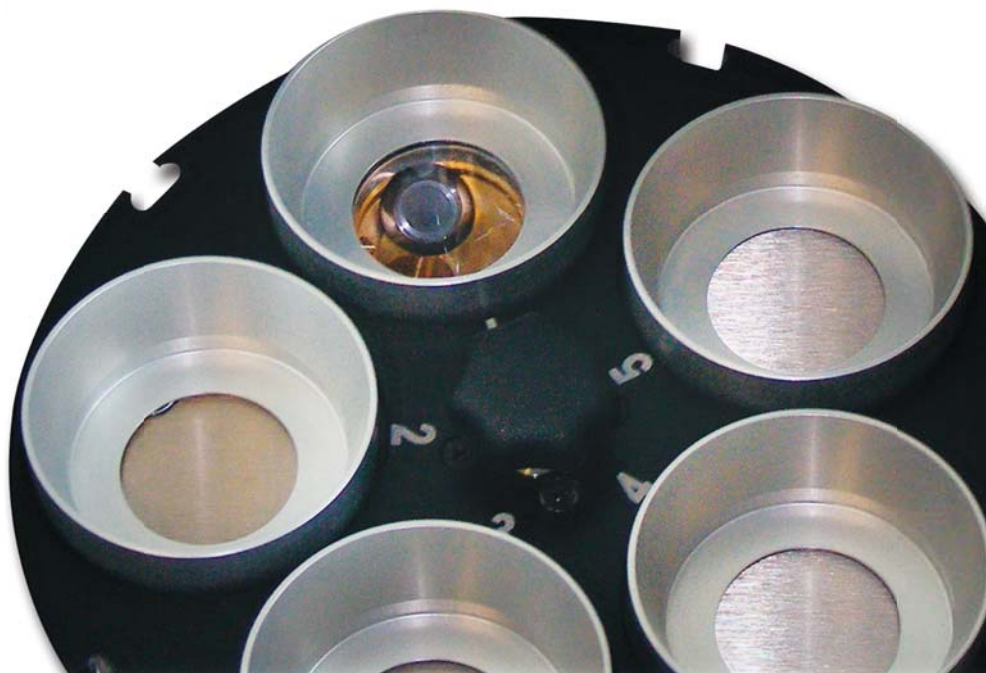

# Versatility Ensures Compliance

## International Test Methods

For the determination of traditional levels of sulfur in crude, bunker fuel, diesel, and other petroleum raw materials and refined products, the Rigaku NEX QC Series offer compliance for:

- ASTM D4294-10: 16 ppm – 5wt%
- ISO 20847: 30 – 500 mg/kg
- ISO 8754: 100 mg/kg – 5wt%
- IP 496: 100 mg/kg – 5wt%
- IP 336: 100 mg/kg – 5wt%
- JIS K 2541-4: 0.01 – 5wt%
- ISO 13032: 8 – 50 mg/kg (NEX QC+ only)

The ability to perform other petroleum-related applications demonstrates the versatility and performance of the NEX QC Series analyzers. For example, analyze multiple elements (P, S, Ca, Zn, Mo, and Ba) in lubricating oils, or measure for lead (Pb) or manganese (Mn) in gasoline.

- ASTM D6481
- ASTM D5059
- ASTM D8252-19 (NEX QC+ only)

## Multi-element Versatility

Rigaku NEX QC Series analyzers are capable of measuring more than just sulfur. Multi-element analysis is essential for detecting crude oil contamination or adulteration through salt and other chlorine-bearing compounds. Left undetected, the presence of chlorine (Cl) can bias the sulfur reading high, and potentially leave the chlorine unnoticed. The NEX QC Series analyzers can detect chlorine and other elements, and correct for the presence of chlorine, so it does not affect the sulfur reading.

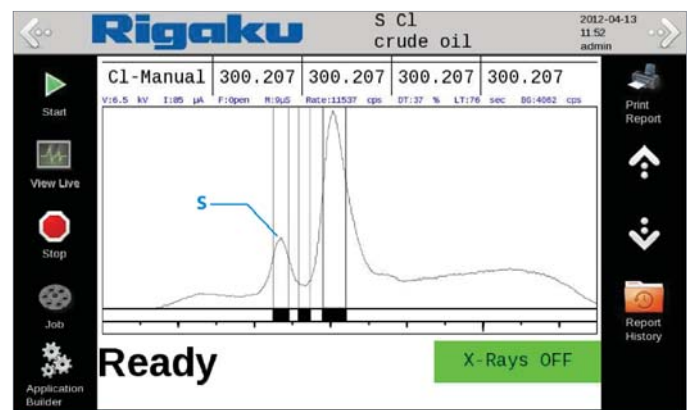

Sweet crude 0.5% S containing no Cl.

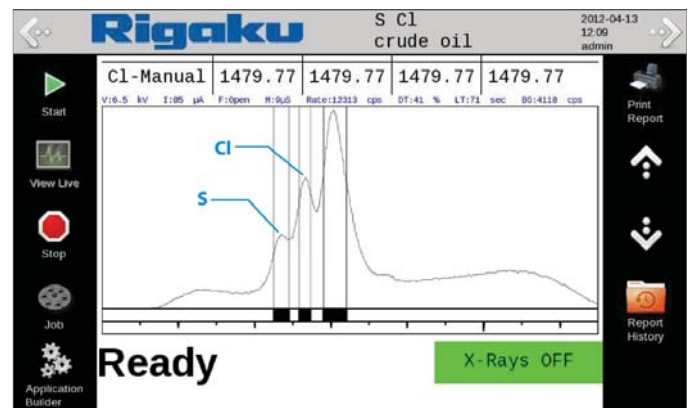

Sweet crude oil contaminated with Cl. Unnoticed and uncorrected, Cl will bias the sulfur reading high.



# Specifications

## Excitation

50 kV X-ray tube
4 W max power
6 tube filter positions

## Detection

High-performance semiconductor detector
Peltier thermo-electric cooling
Optimum balance of spectral resolution and count rate

## Sample Chamber

Large 190 x 165 x 60 mm sample chamber
Single position 32 mm sample aperture
Bulk sample aperture
Analysis in air or helium (optional)

## Environmental Conditions

Ambient temperatures 10 – 35°C (50 – 95°F)
Relative humidity <85% non condensing
Vibration undetectable by human
Free from corrosive gas, dust, and particles

## User Interface

8" WVGA touchscreen interface
Embedded computer
Internal thermal printer
USB and Ethernet connections

## Software

Qualitative and quantitative analysis
Normalization and validation feature
Data export function with LIMS compatibility
User selectable shaping times
Simple flow bar wizard to create new applications
Icon-driven graphical user interface
Password protection
Multi-language

## Options

Single position 40 mm sample aperture
6-position 32 mm automatic sample changer
5-position 40 mm automatic sample changer
Pre-calibrated Sulfur-Paks
Calibration standards
Helium purge

## Warranty



### Our Guarantee

Applied Rigaku Technologies, Inc. offers a 2-year warranty on all EDXRF spectrometers it produces. This industry-leading manufacturer's warranty shows our commitment to quality and displays our dedication to maximizing uptime for our customer's processes and applications.

## Spectrometer Data

Single phase AC	100/240 V, 1.4 A (50/60 Hz)
Dimensions	331 (W) x 432 (D) x 376 (H) mm (13 x 17 x 14.8 in)
Weight	16 kg (35 lbs.)

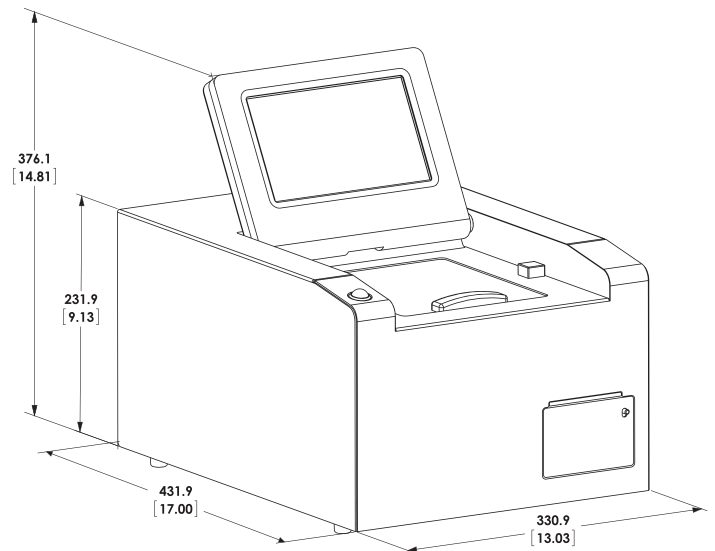

Automatic sample changer configuration.



Single position configuration.

[www.RigakuEDXRF.com](http://www.RigakuEDXRF.com)



**Applied Rigaku Technologies, Inc.**

9825 Spectrum Drive, Bldg. 4, #475, Austin, TX 78717 USA

phone: +1-512-225-1796 | fax: +1-512-225-1797

website: [www.RigakuEDXRF.com](http://www.RigakuEDXRF.com) | email: [info@RigakuEDXRF.com](mailto:info@RigakuEDXRF.com)

**Rigaku Corporation and its Global Subsidiaries**

website: [www.Rigaku.com](http://www.Rigaku.com) | email: [info@Rigaku.com](mailto:info@Rigaku.com)

**NEXQC SERIES**

Petroleum Analysis by X-ray Fluorescence